

# GENERAL SPECIFICATIONS FOR WATER MAIN CONSTRUCTION



## ROLLA MUNICIPAL UTILITIES

102 West 9<sup>th</sup> Street  
Rolla, Missouri 65401  
(573)364-1572

*Approved by Rolla Board of Public Works on April 2, 2019  
Effective April 3, 2019*

# GENERAL SPECIFICATIONS FOR WATER MAIN CONSTRUCTION



*I hereby certify that these specifications were reviewed by me and revised under my direct supervision and that I am a duly registered Professional Engineer in the State of Missouri.*

ROLLA MUNICIPAL UTILITIES  
102 West 9th Street  
Rolla, Missouri 65401  
(573)364-1572

*[Handwritten Signature]*  
04/15/2019

Approved by Rolla Board of Public Works on April 2, 2019  
Effective April 3, 2019

~ TABLE OF CONTENTS ~

	Page
1. GENERAL INFORMATION .....	1
1.1 AUTHORITY AND INTENT .....	1
1.2 DEFINITIONS .....	
2. RESPONSIBILITIES OF OWNER .....	1
3. SERVICES .....	2
4. WATER MAIN MATERIALS .....	3
4.1 PIPE .....	
4.2 VALVES .....	
4.3 VALVE STANDS .....	
4.4 FIRE HYDRANTS .....	
4.5 TRACER WIRE .....	
4.6 SADDLES/CORPORATION STOPS .....	
4.7 METERS .....	
4.8 METER PITS AND VAULTS .....	
4.9 FLUSH HYDRANTS .....	
5. MATERIAL HANDLING .....	6
5.1 PVC PIPE .....	
5.2 PIPE CUTTING .....	
6. LOCATION .....	6
6.1 ALIGNMENT AND GRADE .....	
6.2 WATER MAINS NEAR SEWER .....	
7. EXCAVATION AND PREPARATION OF THE TRENCH .....	6
7.1 SIZE AND ALIGNMENT .....	
7.2 OPEN TRENCH .....	
8. PIPE LAYING .....	7
8.1 LAYING .....	
8.2 JOINTING .....	
8.3 VALVES .....	
8.4 FIRE HYDRANTS .....	
8.5 TRENCHES .....	
8.6 THRUST BLOCKS .....	
9. BACKFILLING .....	8
9.1 UNDER THE PIPE .....	
9.2 IN THE ROADWAY .....	
9.3 IMPERVIOUS TRENCH CHECKS .....	
10. TESTING .....	8
10.1 PRESSURE .....	
10.2 CONNECTIONS TO EXISTING MAINS .....	
10.3 OPERATION OF EXISTING PRESSURIZED VALVES .....	
10.4 DISINFECTION AND FLUSHING .....	
11. INSPECTION .....	9
12. BACKFLOW PREVENTION .....	9
13. RESIDENTIAL AND NON-RESIDENTIAL DEVELOPMENT PROJECTS .....	9
13.1 CONSTRUCTION BY OWNER .....	
13.2 CONSTRUCTION BY RMU .....	
13.3 WATER MAIN EXTENSION PIPE ALLOWANCE .....	
14. DIAGRAMS .....	10

# GENERAL SPECIFICATIONS FOR WATER MAIN CONSTRUCTION

## 1. GENERAL INFORMATION

### 1.1 AUTHORITY AND INTENT

These specifications are drawn and approved by the Rolla Board of Public Works of the Rolla Municipal Utilities, Rolla, Missouri and shall be enforced, and no part thereof altered without approval of said Board or their duly appointed representative. The specifications herein supersede all previous water specifications and drawings issued by Rolla Municipal Utilities (RMU) prior to this date and are subject to change without notice. These specifications are intended to govern all water service supplied by RMU. They are supplementary to, and are not intended to conflict with, any applicable City codes and ordinances. All specifications contained herein apply to Contractors, Developers, Customers, and/or any others who act on behalf of an Owner.

The intent of these specifications is to specify the type and quality of all water main materials, the method and procedure of construction, inspection and testing methods, and the terms of acceptance by RMU of any water main or extension of any main or mains that are or will be an active part of the water system of the Rolla Municipal Utilities, Rolla, Missouri.

Copies of RMU's General Rules and Regulations and water rate and fee schedules are available at RMU's Business Office located at 102 West 9<sup>th</sup> Street, Rolla, Missouri, during normal business hours.

Should there be any questions or comments in regards to these specifications, please contact RMU by phone at (573)364-1572, by fax at (573)364-1540 or email at [info@rollamunicipalutilities.org](mailto:info@rollamunicipalutilities.org).

### 1.2 DEFINITIONS

**RMU:** Rolla Municipal Utilities

**City:** City of Rolla, Rolla, Missouri

**Staff:** Employees of Rolla Municipal Utilities

**Engineer:** Firm employed for engineering purposes

**Inspector:** The technical inspector or inspectors authorized by RMU, limited in each case to the particular duties entrusted to him or them.

**Owner:** or referred to by male gender (i.e. his, him, etc): Any person or company applying for, receiving, using, or accepting water service or any other service supplied by RMU; any Contractor, Developer, or Customer; and/or any person(s) acting on behalf of the Owner; any person owning rights to or sponsoring any work pertaining to water main work, such as a Land Owner or Developer.

**AWWA:** American Water Works Association

**Or Equal:** Any part or fitting submitted to RMU for evaluation and determined by RMU to be equal in quality and performance to any currently specified acceptable manufacturer or series.

## 2. RESPONSIBILITIES OF OWNER

2.1 The Owner or his Engineer shall be responsible for the proper location and grade of any proposed water main extension. Property pins or accurately labeled laths shall be provided at key lot corners, particularly at intersections and curves. The main shall not be located solely from street centerline markers. The street must be cut or filled to final subgrade prior to installation of water main extension. Possible problems with sanitary sewers, manholes, storm sewers, and drop inlets must be marked and sizes and depths indicated. Failure to provide the above requirements will result in suspension of work.

2.2 The Owner shall employ skilled workmen under the supervision of a foreman, experienced in water main construction, or a plumber to install the main. The Inspector or RMU may suspend work until, in their opinion, skilled personnel are provided.

2.3. The Owner shall be responsible for any failure of the main extension that can be attributed to faulty workmanship or defective materials, and for the maintenance of backfilled areas for one (1) year after the completion of the work. The completion date shall be established by RMU, based on the receipt of a satisfactory water sample. The Owner shall be responsible for any payment to RMU for any work RMU personnel must perform to the main in the absence of the Owner during construction and for one (1) full year after completion of work.

2.4 The Owner shall be responsible for providing necessary easements. Failure to provide these documents will result in a refusal of RMU to make service connections to the mains concerned.

- 2.5 The Owner shall have all work finished to RMU's and any other utility or road entity's satisfaction. RMU reserves the right to refuse the work of any Owner which does not meet these specifications.
- 2.6 The Owner shall supply RMU with a twenty-four (24) hour phone number in case of an emergency during the construction and the one (1) year warranty period of work. Owner shall come, when required, in a timely fashion not to exceed twenty-four (24) hours.
- 2.7 Prior to the start of work, Owner will establish the time and date, and will administer a pre-construction meeting. Owner, Contractor, Subcontractors, and RMU Staff shall attend.
- 2.8 Owner will be required to call RMU Staff before starting the job. Owner will also be required to notify the Inspector by 8:15 a.m. if he intends not to work on a given day.
- 2.9 The Owner shall erect and maintain, as required by the conditions and progress of the work, all necessary safeguards for safety and protection. The Owner shall notify owners of adjacent utilities when prosecution of work may affect their facilities.
- 2.10 No work shall be done between 7:00 p.m. and 7:00 a.m., nor on Saturdays, Sundays or legal holidays observed by RMU without the permission of RMU. However, emergency work may be done without prior permission.
- 2.11 All installations that are connected to the RMU system shall be made in accordance with the codes of the City and RMU specifications. Service will not be rendered to new or remodeled locations until all installations have been inspected and approved by RMU and the City. No portion of the work shall be backfilled until full inspection by RMU. No fitting shall be covered until RMU has inspected its installation, and has had the opportunity to accurately map its location.
- 2.12 Owner shall be responsible for flushing new domestic and fire service lines prior to connection to the internal building plumbing. Owner must contact RMU for RMU to operate all valves 2" and larger. Owner or their contractor shall not operate RMU system valves unless required in a emergency.
- 2.13 Rolla City Code Section 35, Article XIII requires that any wells serving a property be plugged in accordance with Missouri Department of Natural Resources regulations once a connection is made to the public water supply. Should the Owner of said property not comply with this section, RMU reserves the right, and shall disconnect water service until such time the well has been plugged, and inspection and approval by RMU has been obtained.

### 3. SERVICES

- 3.1 Prior to receiving water service from RMU, an account for utility billing must be established. The Owner will be responsible for obtaining any necessary excavation permits from the City of Rolla, Missouri Department of Transportation or others as may be necessary before the work begins. The Owner is also responsible for contacting Missouri One-Call in advance of the work so that existing utilities can be located. The Owner must contact RMU at least two(2) business days prior to any taps being made. *The fees for taps are detailed in the Rates and Fees section of RMU's General Rules and Regulations.*
- 3.2 The Owner shall, at his own expense, dig and fill the trench, furnish and install the service line While RMU is responsible for maintenance of service lines in ROW, the Owner is responsible for any costs associated with making upgrades to service lines within the ROW. Said service line shall be at least twenty-four (24) inches beneath the finish grade. The Owner will be responsible for any and all injury and/or damage in consequence thereof or resulting therefrom. At no time shall any line be tapped directly into a fire line or fire hydrant lateral, unless approved by RMU.
- 3.3 The portion of the service line located beyond the meter and on private property shall be installed in accordance with Rolla City Building Codes.
- 3.4 All attachments and appurtenances used in supplying water from the water main to the dwelling or structure must be supplied by the Owner. The water meter box and its appurtenances shall be placed on private property in a location acceptable to RMU.
- 3.5 All service lines and fire lines, from the water main up to five (5) feet beyond the water meter (or tap for fire service lines) or any portion of the service line that is located in City right-of-way, shall be constructed using

only materials approved by RMU. For all service and fire lines 2" and smaller, the service line from the main to the meter shall be continuous piping with no splices, unless pre-approved by RMU. No service line or fire line for which RMU may be responsible shall be covered until the installation has been inspected by RMU.

- 3.6 All service lines and fire lines, from the water main to a point at least five (5) feet beyond the water meter (or any for fire service lines) or any portion of the service line that is located in City right-of-way, shall be installed with a tracer wire. *Refer to Section 4.5 for Tracer Wire materials and detailed drawings for more information.*
- 3.7 When a new service line is being installed for a new metering location with one (1) water meter, the service line from the main to the meter shall be a minimum ¾" in diameter. The service line shall be a minimum 1" in diameter when the service line will be supplying a single pit with two (2) meters ( a double meter set). The Owner will be required to comply with Rolla City Building Codes if larger service lines are necessary. If multiple meters are installed in a single pit, the pit shall be placed along the shared property line between the two (2) properties being served.  
If the Owner desires to revise the number of water meter(s) serving a property (such as converting a single occupancy building to a multiple tenant building) the Owner will be responsible for all costs associated with this change, except the meter(s) RMU will provide. RMU does not provide any warranty that any existing service line (both before and after the meter) is sized adequately to provide service for the planned usage.
- 3.8 Rolla Municipal Utilities shall be responsible for maintaining all water lines located within the public right-of-way, including the water main, main taps, pipe, laterals, fittings and valves between the main and the edge of the right-of-way. The Owner or occupant of the premises shall be responsible for perpetual maintenance of customer service lines and appurtenances outside the public right-of-way.
- 3.9 The only equipment allowed within the RMU supplied water meter box is the RMU furnished water meter and its associated valves and fittings.
- 3.10 The Owner must coordinate installation of fire service lines with RMU and the City of Rolla fire Department. Where installation takes place within right-of-way the piping must be C-900 PVC, DR 14. All materials installed in the right-of-way and the connection to RMU water mains must be in accordance with the applicable sections of these specifications and the installation shall be inspected by RMU
- 3.11 Where a single structure requires both domestic and fire sprinkler service, fire line and domestic service lines shall be extended to the RMU water main and separate taps shall be made for each.
- 3.12 Before a new service is activated, a permit shall have been issued by the City of Rolla Codes department, if applicable. RMU will temporarily activate a fire or other service line(s) as needed for testing backflow prevention devices or pressure testing lines in order to close-out a permit, otherwise the line will be inactive .

#### 4. WATER MAIN MATERIALS

##### 4.1 PIPE

All pipe shall meet one of the following specifications:

- 4.1.1 PVC PIPE - PVC is the preferred material to be utilized for all water main extensions. PVC pipe, 4" through 12" diameter, shall be C-900, Class 305-DR14. 16" PVC pipe shall be C905, Class 235 - DR18. All PVC pipe shall be made from ASTM D1784 Class 12454-A or Class 12454-B compounds as defined and set forth in AWWA Standards relating to PVC water distribution pipe. The PVC compounds used to manufacture said PVC pipe shall contain no ingredient in any amount that has been demonstrated to migrate into water in quantities considered to be toxic. Gaskets and lubricants intended for use with PVC pipe and couplings shall be made from materials that are compatible with the plastic material and with each other when used together. The materials shall not support the growth of bacteria nor adversely affect the potable quality of the water that is to be transported.
- 4.1.2 FITTINGS - All fittings, regardless of type of pipe to be used, shall be SSB-Ductile Iron, Class 350, ANSI/AWWA C153/A21.53 specification, and shall be mechanical joint, cement lined, bituminous or fusion bonded epoxy exterior coated.
- 4.1.3 CERTIFICATION - All pipe shall carry the NSF approved (by stamp on pipe) for potable water.
- 4.1.4 MINIMUM PIPE SIZE - The minimum pipe size for new water mains is eight (8) inches. RMU will review requests for installation of water mains smaller than eight (8) inches on a case-by-case basis.

On principal streets and for all long lines, the diameter of the water mains will be determined by RMU.

#### 4.2 VALVES

- 4.2.1 2"-12" INCLUSIVE - Valve sizes, two (2) inch thru twelve (12) inch inclusive shall meet the latest edition of the AWWA C509 and shall be non-rising stem, mechanical joint, with a resilient seated wedge that is fully encapsulated in rubber permanently bonded to the wedge. Valve shaft shall have "O" ring seal, and two (2) inch square operating nuts. Valve shall open in a counter-clockwise direction. Valve body and bonnet shall have a fusion bonded epoxy coating. All plugs, bolts and nuts shall be stainless steel. Approved manufacturers are Mueller, AVK, American Darling, Clow, and Kennedy.
- 4.2.2 16" AND LARGER - Valve sizes, sixteen (16) inch and larger shall meet the latest edition of the AWWA C504 and shall be butterfly, mechanical joint type with rubber-seated, self adjusted disc seal with 2" square operating nut opening counter-clockwise. Approved manufacturers are Mueller and Clow.
- 4.2.3 TAPPING VALVES - Tapping valves shall be in accordance with Section 4.2.1 for use with specified Powerseal 3490, Ford FTSS or JCM 439 Type 304 stainless steel, mechanical joint tapping sleeve.
- 4.2.4 LOCATION, SIZE AND QUANTITY OF VALVES - Location, size and quantity of valves shall be as specified by RMU.
- 4.2.5 Valves will be installed as required by RMU to facilitate main isolation. Valves shall generally be installed at connections with other mains and at either side of major ditch or highway crossings. In cases of long pipe segments, valve(s) will be required where needed such that the distance between valves will generally be 1,000 feet or less.
- 4.2.6 CERTIFICATION - All valves shall carry the NSF approved (by stamp on valve) for potable water.

#### 4.3 VALVE STANDS

Valve stands shall be two piece, twenty-four (24) inch minimum, screw type, bottom section and sixteen (16) inch screw type, top section complete with lid marked "WATER".

#### 4.4 FIRE HYDRANTS

- 4.4.1 THREE-WAY HYDRANTS - All three-way fire hydrants shall fully conform to AWWA C-502 and shall be Mueller Centurion, #A-423, Clow Medallion or AVK Series 2780, 5-1/4" valve with six (6) inch mechanical joint shoe, to meet Rolla Municipal Utilities' specifications on file with the manufacturer. All three-way fire hydrants shall be adapted with one 4-1/2" "Steamer" connection as pumper nozzle and two 2-1/2" hose connections (four threads per inch). All hydrants are to be safety yellow in color. Forty-two inch depth of bury shall be standard, however, individual conditions may warrant deviation. Any deviation in depth shall be approved by RMU. *Refer to Detail #8.*
- 4.4.2 TWO-WAY HYDRANTS - Two-way fire hydrants shall be used on all mains 12" and larger, shall fully conform to AWWA C-502 and shall be Clow Medallion, Mueller #A425 or AVK Series 2756, 5-1/4" valve with six (6) inch mechanical joint shoe to meet Rolla Municipal Utilities' specifications on file with the manufacturer. All two-way fire hydrants shall be adapted with two (2) 4-1/2" "Steamer" connections as pumper nozzles (4 threads per inch). All hydrants are to be safety yellow in color. Forty-two (42) inch bury shall be standard, however individual conditions may warrant deviation. Any deviation in depth shall be approved by RMU. *Refer to Detail #8.*
- 4.4.3 ADEQUATE FIRE FLOW - The maximum separation between fire hydrants in Residential areas shall not exceed 500 feet, and in those areas designated as Non-Residential, the maximum separation between hydrants shall not exceed 300 feet. In order to provide adequate fire flow, a minimum pipe size of eight (8) inches in new developments shall be required, except where special conditions warrant otherwise.
- 4.4.4 EXTENSIONS - The Owner shall be responsible for installation of fire hydrant extensions required to elevate fire hydrants to ground level. This responsibility shall continue for one year after completion of the system extension installed by the Owner.

4.5 TRACER WIRE

A tracer wire shall be installed on all newly constructed water mains and polyethylene service lines to facilitate the detection of said waterlines. *Tracer wire shall be positioned and installed as shown in Detail #9.* Tracer wire shall be THNN, 12 gauge copper wire, solid blue in color, or equal as may be approved by RMU. All wire shall be joined by use of a waterproof wire connector (3M Direct Bury Splice Kit #DBR/Y-6). For services connected to existing mains, tracer wire shall be connected using a Blackburn 9H split bolt with a GEL kit (GHFC-1-SBC-OFCB100). All material shall be that normally used for direct underground bury installation.

4.6 "T" BOLTS - "T" bolts used with valves with open notch bolt holes must be anti-rotation with square shank.

4.7 TAPPING SLEEVES - Tapping sleeves shall be Powerseal 3490, Ford FTSS or JCM 439 Type 304 stainless steel mechanical joint for PVC and ductile iron pipe. Tapping sleeve must include a test port to facilitate the required air pressure test before the existing main is tapped.

4.8 SADDLES/CORPORATION STOPS

Corporation stops shall be Ford F1000 or AYM 74701G series with AWWA taper thread inlet and copper grip outlet. For all diameters of PVC pipe, Ford style 202BS or AYM8845 double band brass saddle clamps shall be used. These clamps shall be totally of brass and stainless steel with AWWA taper thread.

4.9 METERS

Water meters and strainers, up to and including 3", will be furnished by RMU unless other special arrangements are made in advance. When new services require a meter 4' or larger, the Owner shall furnish and install a meter, strainer and other materials that are approved by RMU. All meters supplied by the Owner shall be compatible with the expected flow conditions and compatible with RMU's meter reading system. RMU will provide recommendations to the Owner in regards to the meter size. RMU will be responsible for determining the type of meter to be installed. RMU will be responsible for future maintenance of all meters after inspection and approval of the installation.

4.10 METER PITS AND VAULTS

Meter pits and vaults shall be located as close as practical to the water main to minimize the amount of service line between the main and the meter. When the main is located in City right-of-way, the meter pit or vault shall be installed adjacent to the right-of-way line on the private property side of the right-of-way line, unless otherwise approved by RMU. When the water main is on private property in an easement the meter pit of vault will typically be installed at the edge of the easement unless otherwise approved by RMU. New meter pits shall be located such that the pit and materials within the pit will be accessible to RMU staff for maintenance.

If the meter pit or vault is installed in a hard surfaced area, such as a driveway, parking lot, or sidewalk surfaced with asphalt or concrete, the lid shall be flush with the hard surface. If the Owner adjusts the hard surface, the Owner will be responsible for adjusting the meter ring and lid as necessary. Meter pits or vaults installed in a concrete area must be constructed such that there are construction joints in the concrete to allow for removal of the ring and lid.

For a new installation where the service will be a direct customer of RMU, the meter pit, ring, and lid will be provided by RMU for installation by the Owner for locations with 2" or smaller meters and where the pit is not located in a traffic area. The Owner will provide and install all materials for metering locations with 3" and larger meters and locations subject to traffic. For all customers located such that the property will be served by Phelps Count Public Water Supply District Number 2, the Owner will be required to provide all materials (other than the meter).

Meter vaults for meters 3" and larger shall include a lid large enough to allow a person to enter the vault for maintenance, if needed. The lid must be rated for traffic if installed in an area subject to traffic.

For residential meter locations where two (2) meters are or can be installed in a single pit, the water meter pit shall be installed at the property line between adjacent lots, unless an alternate location is approved by RMU.

4.11 FLUSH HYDRANTS

Flushing hydrants shall be non-freezing, self-draining type with a minimum 36" bury. These hydrants will be furnished with a 2" FIP inlet, a non-turning operating rod, and shall open to the left. All of the working parts shall be of bronze-to-bronze design, and be serviceable from above grade with no digging. The outlet shall also be bronze and be 2-1/2" NST. Hydrants shall be lockable to prevent unauthorized use as manufactured by Kupferle Foundry Co., or RMU approved equal. *Refer to Detail #11.*

## 5. MATERIAL HANDLING



**5.1 PVC PIPE**

PVC pipe shall be handled according to guidelines set out in AWWA M23. The pipe shall not be handled with individual chains or single cables, even if padded. They shall not be dropped to the ground or into the trench and shall not be dropped or rolled against other objects on the ground. Gaskets shall be protected from excessive exposure to direct sunlight, ozone, oil and grease. If stored for extended periods, the pipe shall be protected from direct sunlight and shall be laid so as not to become deformed or bent.

**5.2 PIPE CUTTING**

Cutting for closure or for other reasons shall be done in a neat, workmanlike manner by methods which will not damage the pipe. The outside edge must be beveled and smoothed to prevent gasket damage when cut for insertion into spigot. Bevels shall be cut off square for insertion into fittings.

**6. LOCATION****6.1 ALIGNMENT AND GRADE**

The water mains shall be laid and valves, hydrants and fittings shall be placed in accordance with the plans. All water mains are to be installed at a minimum depth of forty-two (42) inches below finish grade to the top of the main.

**6.2 WATER MAINS NEAR SEWERS**

6.2.1 HORIZONTAL SEPARATION - The water main shall be laid at least ten (10) feet horizontally from any existing or proposed storm or sanitary sewer line. Should local conditions prevent a lateral separation of ten (10) feet, water main may be laid closer than ten (10) feet to a storm or sanitary sewer, provided that the main is laid in a separate trench or on an undisturbed earth shelf located on one side of the sewer line and at such an elevation that the bottom of the water main is at least 18" above the top of the sewer line. Backfill shall be compacted to a minimum of eighteen (18) inches over/under water main.

6.2.2 VERTICAL SEPARATION - Where water mains must cross over storm drains or sanitary sewers, the water main must be laid at such an elevation that the bottom of the water main is at least eighteen (18) inches above the top of the sewer, and a full length of water pipe must be centered over the sewer to be crossed so both joints will be equally distant from the sewer and as remote therefrom as possible. The vertical separation must be maintained for that portion of the main located within ten (10) feet horizontally of any storm drain or sanitary sewer that it crosses, said ten (10) feet to be measured as the shortest distance from the water main to the sewer at that point. Backfill shall be compacted to minimum of eighteen (18) inches above the outside dimension of the water main and for a horizontal distance of ten (10) feet from the sewer being crossed.

6.2.3 UNUSUAL CONDITIONS - Where conditions prevent the minimum horizontal and/or vertical separation as set forth above from being maintained or where it is necessary for the water main to pass under a sewer line, the water main must be backfilled with a compacted clay to a minimum of eighteen (18) inches above and below the outside dimension of the sewer being crossed. In making such crossings, a full length of pipe must be centered over or under the sewer to be crossed so that the joints will be equally distant from the sewer and as remote therefrom as possible. Where a water main must cross under a sewer, a vertical separation of at least eighteen (18) inches between the bottom of the sewer line and the top of the water main must be maintained, with adequate support for the larger size sewer lines to prevent them from settling. Where these conditions cannot be met, and to meet Missouri Department of Natural Resources requirements, either the water line or the sewer line shall be installed in a continuous casing that extends at least 10' beyond the area where the minimum separation could not be obtained. In no case shall the water main and the sewer main share the same granular fill bed.

**7. EXCAVATION AND PREPARATION OF THE TRENCH****7.1 SIZE AND ALIGNMENT**

The trench shall be dug such that the pipe can be laid to the proper grade and alignment as shown on the approved plans. Width of trench shall be so as to have a minimum of twelve (12) inches greater than the outside of the pipe. Bell holes shall be provided at each joint to permit proper jointing and ensure the pipe is supported evenly along the entire length of the barrel. Bedding of PVC pipe is especially important. The trench for PVC pipe shall be over dug to a minimum of three (3) inches and backfilled with granular material

(maximum particle size of 3/4") to provide continuous support for the pipe. Select material, containing no particle larger than two (2) inches, shall be placed around and to a minimum depth of twelve (12) inches above the top of the pipe. Hand excavation shall be employed in trenching when deemed necessary by RMU.

7.2 OPEN TRENCH

At no time shall there be more than 300 feet of trench opened in advance of the pipe laying operations and this length of open trench may be shortened by order of RMU.

8. PIPE LAYING

8.1 LAYING

All pipes, fittings, valves and hydrants shall be carefully lowered into the trench by means of ropes or mechanical equipment. Ends of all pipe must be thoroughly cleaned.

After placing a length of pipe in the trench, the spigot end shall be centered in the bell, the pipe forced home and brought to proper grade and alignment. The pipe shall be secured in place with proper backfill material tamped around and over it at the bells. Bells shall be in the direction of the laying operations.

During lunch breaks, at night, or any time that work is delayed, the open end of the line must be plugged to prevent the entrance of water, debris, small animals and/or rodents.

All joint deflections must be within the pipe manufacturer's recommendations, and are hereby included and made a part of these specifications by reference. PVC pipe may be deflected around curves so long as deflection is in the joint only. No strain shall be placed on the pipe for the purpose of deflection. Manufacturers may vary in the amount of deflection which can be obtained in the pipe joint and their specifications should be consulted. In the absence of manufacturers specifications, use 1.5 degrees per twenty (20) foot section in the following schedule.

Blocking is not recommended, but if necessary, the pipe barrel must be supported in at least three places. No pipe or fittings shall be laid in or under water.

ALLOWABLE PVC PIPE DEFLECTION FROM JOINT ONLY

<u>Degree of Deflection in Joint</u>	<u>Offset per 20' Section in inches</u>	<u>Min Radius of Curvature</u>
5	21	230 feet
3	12	380 feet
2	8	570 feet
1.5	6	760 feet

8.2 JOINTING

All joints must be made as per manufacturer's and AWWA specifications.

8.3 VALVES

Valves shall be located as designated by RMU and the approved plans, and at all fire hydrants.

8.3.1 All valves shall be protected by a valve stand, the top of which shall be to the same elevation as the finish grade.

8.3.2 All valves shall be installed in an upright position, not to lean in any direction.

8.3.3 all valves shall be installed as close as possible (less than three (3) feet ) to any fittings associated with the valve installation, and to the intersection of water mains where the placement of a valve is required, or in other locations as directed by RMU.

8.3.4 All valves associated with a tee or cross shall be restrained as described in Detail #13.

8.4 FIRE HYDRANTS

Fire hydrants shall be located as designated by RMU. During construction and prior to final acceptance of the water system by RMU, all fire hydrants shall be covered to indicate that the hydrant is not available for fire protection.

8.5 TRENCHES

The water main trench shall be reserved for the installation of the water main and associated valves and fittings. Other utilities of private facilities shall not be located or installed in the same trench as the water mains.

8.6 THRUST BLOCKS

Thrust blocks shall be cast in place at each change in direction of a pipe line and at all tees, hydrants, plugs, caps and bends. *Refer to Detail #1.*

## 9. BACKFILLING

### 9.1 UNDER THE PIPE

All backfill under the barrel of the pipe shall be free from debris, organic matter, and stones larger than one (1) inch in diameter in the greatest direction, and shall be tamped in place. Crushed stone aggregate (100% passing a 1" screen, 95% passing a ¾" screen and not more than 5% passing a No. 4 screen) are acceptable substitutes for soil. (Refer to detail #12)

### 9.2 IN THE ROADWAY

For PVC pipe, ditches within the road right-of-way are to be backfilled the entire depth with one (1) inch clean gravel to the top of the ditch in six (6) inch to twelve (12) inch lifts. The compaction of this backfill will be 95% of original density.

### 9.3 IMPERVIOUS TRENCH CHECKS

9.3.1 Trench checks shall be placed at intervals as required by RMU in locations where necessary.

9.3.2 Trench checks shall extend the full width of the trench. Trench check material shall be placed completely under, around and above pipe, and shall be placed in maximum compacted lifts of 8 inches in thickness and compacted to 95% of maximum density as determined by ASTM D698. Extreme care shall be used in compaction operations to prevent compacting equipment from contacting the pipe. (Refer to Detail #10)

## 10. TESTING

### 10.1 PRESSURE

After the pipe has been laid and backfilled, all newly laid pipe or any valved section thereof shall be pressure tested and leakage tested in accordance with the latest AWWA standard.

### 10.2 CONNECTIONS TO EXISTING MAINS

Solely at the discretion and permission of RMU, competent party or parties other than RMU personnel, may be allowed to make taps or connections to an existing main. RMU personnel must be present at the time of tap or connection. Owner shall give RMU no less than two (2) business days notice prior to undertaking any work to make a connection to an existing main.

### 10.3 OPERATION OF EXISTING PRESSURIZED VALVES

All valves under pressure in the mains supplied by RMU shall be operated only by employees of RMU, except in cases of extreme emergency or by special permission from RMU.

### 10.4 DISINFECTION AND FLUSHING

10.4.1 All disinfection and chlorination will be done by Owner in accordance with the latest version of AWWA C-651. Liquid chlorine or chlorine gas are not permitted. A copy of AWWA C-651 is available at the RMU Business Office or RMU Service Department.

10.4.2 Sampling taps to be provided by the Owner at a minimum of one per 1,200 feet or as directed by RMU and one at each end of the line. Sampling tap to be constructed as shown in Figure 2 of AWWA C-651 or approved equal. Use of hose or fire hydrant for collection of sample will not be permitted.

10.4.3 Disinfecting media shall be placed in a manner and in amounts as specified by RMU. Bacteriological samples shall be collected under the supervision of RMU. The samples shall be analyzed by a representative of a laboratory, which has been certified by MoDNR to make said analysis.

10.4.4 Owner will be required to re-chlorinate lines in accordance with AWWA C-651 for sections not meeting MoDNR bacteriological requirements.

10.4.5 Water from the new main will be flushed by RMU personnel. The Owner shall provide means to de-chlorinate the heavily chlorinated water in accordance with requirements of AWWA C651 and any federal, state or local regulatory agencies. Only upon safe bacteriological sample notification will new

main be put into service.

- 10.4.6 RMU reserves the right to charge the Owner for excess water required to flush and test new water main(s) installed by the Owner if an excessive amount of water is required for completion of flushing and disinfecting and new main(s).

## 11. INSPECTION

- 11.1 It shall be agreed upon by all parties that RMU staff shall have full authority of inspection at all times during the progress of any water main work. The Inspector shall have full authority to inspect material and the work performed.
- 11.2 The Owner shall provide all reasonable aid and assistance required by RMU, Engineer, and/or Inspector for the proper inspection and examination of the work and all parts thereof.
- 11.3 Engineers, Inspectors and other properly authorized representatives of RMU shall be free at all times to perform their duties, and intimidation or attempted intimidation of any one of them by the Owner or by any of his employees shall be sufficient reason, if RMU so desires, for suspension of work.
- 11.4 Such inspections shall not relieve the Owner from any obligation to perform his work in accordance with these specifications or any approved plans, and work not so constructed shall be removed and made good by the Owner at his own expense, whenever ordered by the Inspector without reference to any previous oversight or error in inspection.
- 11.5 It shall be the responsibility of the Owner to contact RMU as to when any work is to commence, thereby allowing for the inspection of work to commence.

## 12. BACKFLOW PREVENTION

- 12.1 Backflow prevention devices shall be provided by the Owner in accordance with 10 CSR 60-11 of the Missouri Safe Drinking Water Regulations.
- 12.2 Backflow prevention devices shall be installed at a location and in a manner approved by RMU and shall be installed at the expense of the water consumer. These devices shall be located on the consumer's side of the water meter and prior to any other connection.
- 12.3 Backflow prevention devices shall be located so as to be readily accessible for maintenance and testing, protected from freezing and where no part of the device will be submerged or subject to flooding by any liquid. When the backflow prevention device is installed in a pit, the pit must have a 4" drain to daylight or to a storm drain.
- 12.4 Backflow prevention devices shall be tested yearly in accordance with Missouri 10 CSR 60-11. A copy of the test report shall be forwarded to RMU.
- 12.5 In the event a backflow prevention device is removed, RMU requires written notification regarding the removal and reason for the removal.
- 12.6 Violators of the provisions in Section 12 may cause service to be refused and/or disconnected. Upon the discontinuance of service for any reason, RMU shall have the right to enter the premises and remove RMU property. RMU also reserves and shall have the right to interrupt or deny service without prior notice for reasons of maintenance, health, safety or state of emergency, (including unauthorized interference, diversion or use of service), or in cases where RMU is directed to disconnect service by a governmental agency or officer. In such cases, RMU will make a reasonable effort to inform the Owner of the reasons for disconnection of service.

## 13. RESIDENTIAL AND NON-RESIDENTIAL DEVELOPMENT PROJECTS

### 13.1 CONSTRUCTION BY OWNER

The Owner shall contact RMU when beginning the planning and permitting processes for developments in Rolla. RMU will examine your project in relationship to existing facilities and work with the Owner to coordinate the layout of all proposed water system improvements..

When it becomes necessary to make a water main extension to the RMU water distribution system to serve

new customers in subdivisions, along dedicated streets or roads, or in approved dedicated easements within the City, prior to any work, a preliminary drawing shall be submitted to RMU for its consideration. Upon receipt of these drawings, RMU will make any changes deemed necessary. RMU will stipulate the size and location of the pipe and the number and location of fire hydrants and valves. RMU will then return said drawings to the Owner for correction. The Owner shall make the indicated corrections and resubmit the drawings to RMU for final approval. The approved submittals and drawings, along with the appropriate application, will be submitted to the Department of Natural Resources for final review and approval. Two (2) sets of the final drawings shall be submitted to RMU. Any permit fees are the responsibility of the Owner. No work or installation of any sort may commence until such time as the Missouri Department of Natural Resources has reviewed the development plans and issued the proper permit(s).

After the extension is completed and accepted, RMU will pay the Owner, a pipe allowance, established by the Rolla Board of Public Works, to compensate them for a portion of the cost of the water main extension. No pipe allowance will be paid for water mains 8" in diameter or smaller or for lateral lines installed solely for the purpose of serving the needs of an individual or a corporation, such as a sprinkler system, shopping center, multi-family dwelling, nursing home, manufacturing facility, etc.

13.2 CONSTRUCTION BY RMU (That results in frontage fees being due from property owner later)

When it becomes necessary to make a water main extension to the RMU water distribution system to serve new customers or to provide fire protection, RMU will construct the extension in accordance with RMU specifications. The total cost of the extension will be recorded by RMU and the pro-rated cost will be determined at the time the extension is made by taking the total cost of the extension less a pipe allowance applicable to the size of the main. The cost per foot divided by the total amount of frontage, will equal the pro-rated cost per foot for each side of the main. Corner lot frontage will be determined by taking an average of all frontage sides of that corner lot.

Owners who request and/or receive service directly from the water main extension will pay the pro-rated cost per foot to connect to the system prior to being connected to the water main extension.

13.3 WATER MAIN EXTENSION PIPE ALLOWANCE

*Refer to the section marked "Fees" located at the back of these specifications.*

**14. DIAGRAMS**

The Detail Sheets contained herein illustrate items of text, and various equipment and installations. Further details on these and other types of service arrangements may be obtained from RMU. All installations must comply with these specifications, local ordinances and other requirements.

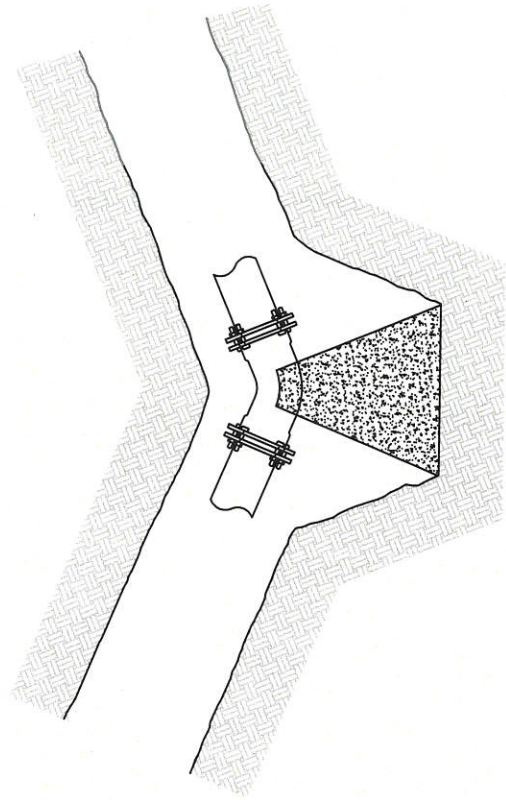
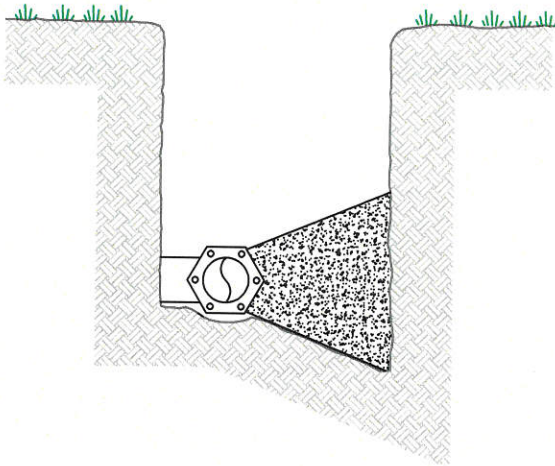

**Notes:**

1. Thrust blocks shall be cast-in-place at each change in the direction of a pipe line and at all tees, plugs, caps and bends. Use 4,000 psi concrete mix.
2. Backing shall be placed between solid ground and the fitting to be anchored and shall be of such bearing areas as to assure adequate resistance to the thrust to be encountered.
3. Before concrete is poured, the fitting to be anchored is to be covered with 3 mil polyethelene to such extent as to insure that at no time will any of the concrete come into contact with any portion of the fitting to be anchored or its accessories.

**REACTION BACKING**

**BEARING AREA:** SQUARE FEET AGAINST TRENCH WALL (BASED ON WATER PRESSURE OF 150 PSI AND ALLOWABLE SOIL PRESSURE OF 1000 PSF).

PIPE SIZE	TEE & PLUGS	HYDRANTS & 90° ELLS	WYES & 45° ELLS	22 1/2° ELLS	11 1/4° ELLS
4"	3	4	2	1	1
6"	6	8	4	2	1
8"	10	14	7	4	2
10"	15	21	11	6	3
12"	21	29	16	8	4
16"	36	50	27	14	7

**ROLLA MUNICIPAL UTILITIES**  
 102 WEST 9TH STREET  
 ROLLA, MISSOURI 65401

**THRUST BLOCK DETAIL**



**WATER SPECIFICATIONS**  
 DETAIL #01

SCALE N/A REVISION DATE 03-18-2019

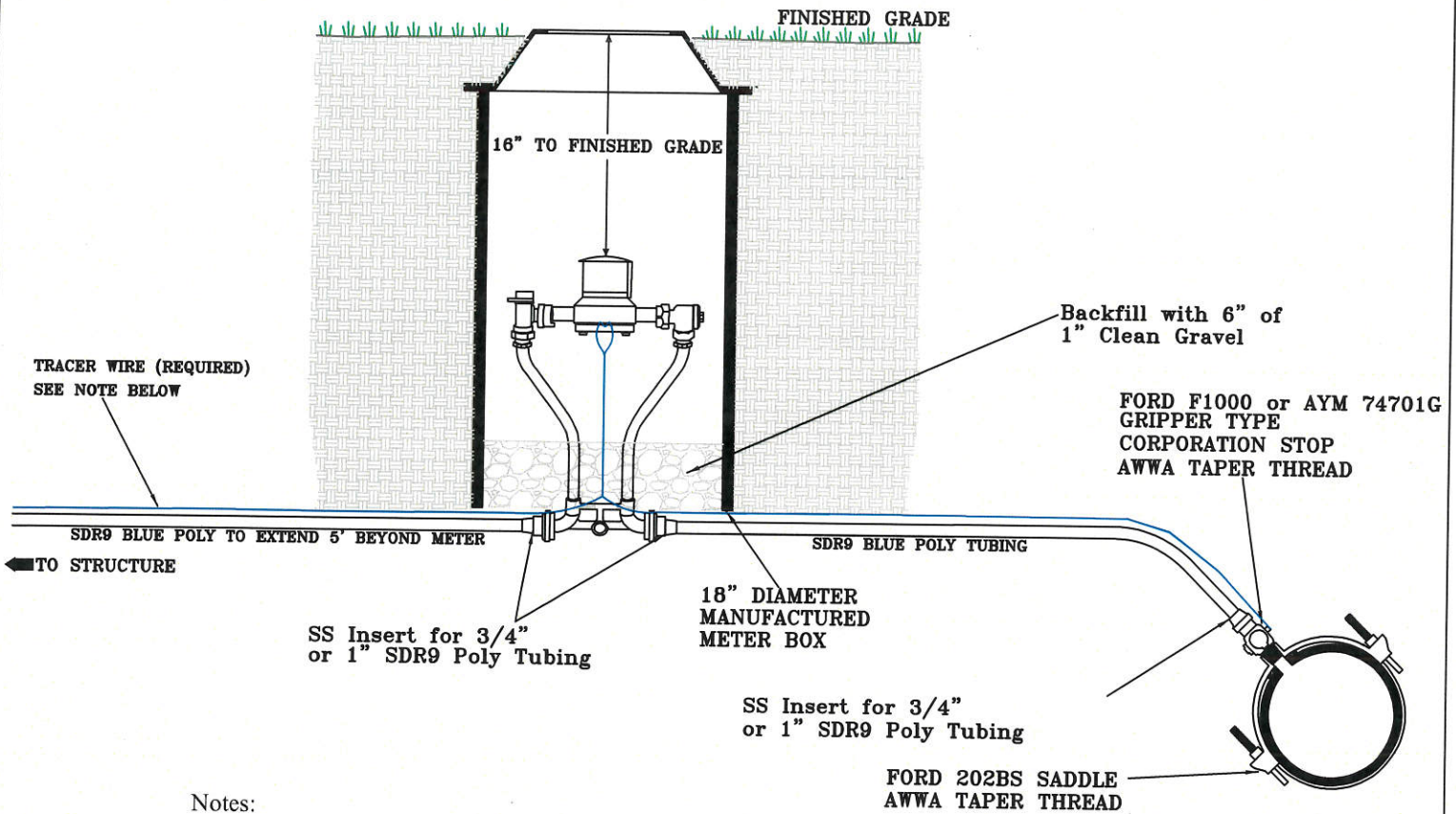

Notes:

1. For a 5/8" meter (standard lay length of 7 $\frac{1}{2}$ " ) on a single meter set, as shown, meter set shall be Ford VBH71-18W-14-33-G-NL or AYM 721-118WCGG 33 with 3/4" gripper inlet and 5/8" meter outlet.
2. For a 1" meter (standard lay length of 10 $\frac{3}{4}$ " ) on a single meter set, meter set shall be a Ford VBH74-18W-44-44-G-NL or AYM 721-418WCGG 44 with a 1" gripper inlet and 1" meter outlet.
3. A double meter set will require a branch piece (Ford U48-43G or AYM 7080GM) and two meter sets (Ford VBH71-18W-14-33-G-NL or AYM 720-118WCDQ 33). A section of all-thread and four nuts shall be installed through the bases of the two meter sets on a double service installation for support.
4. SDR9 Blue Poly tubing, 200 PSI, shall be used for service line. Size 3/4" shall be used for a single 5/8" meter set and 1" shall be used for either a double 5/8" meter set or a 1" meter set.
5. SDR9 Blue Poly tubing shall have a stainless steel (SS) insert (1" or 3/4") at each connection.
6. Corporation stops shall be Ford F1000 series or AYM 74701G with AWWA taper thread inlet and copper grip outlet. For all diameters of PVC pipe, Ford style 202BS double band brass saddle clamps shall be used. These clamps shall be totally of brass and stainless steel with AWWA taper thread.
7. For a new installation where the service will be a direct customer of RMU the meter pit, ring, and lid will be provided by RMU for installation by the Owner where the pit is not located in a traffic area. For all customers located such that the property will be served by Phelps County Water Supply District Number 2 the Owner will be required to provide all materials (other than the meter).
8. A meter by-pass assembly will not be allowed.
9. Tracer wire is required on poly tubing with at least 5' inside meter pit. It is recommended to install tracer wire from meter pit to structure. See detail #9 for installation.

<b>ROLLA MUNICIPAL UTILITIES</b> 102 WEST 9TH STREET ROLLA, MISSOURI 65401	
<b>5/8" TO 1" METER</b>	
	<b>WATER SPECIFICATIONS</b> <b>DETAIL #02</b>
SCALE <u>N/A</u> REVISION DATE <u>03-18-2019</u>	

PLAN VIEW

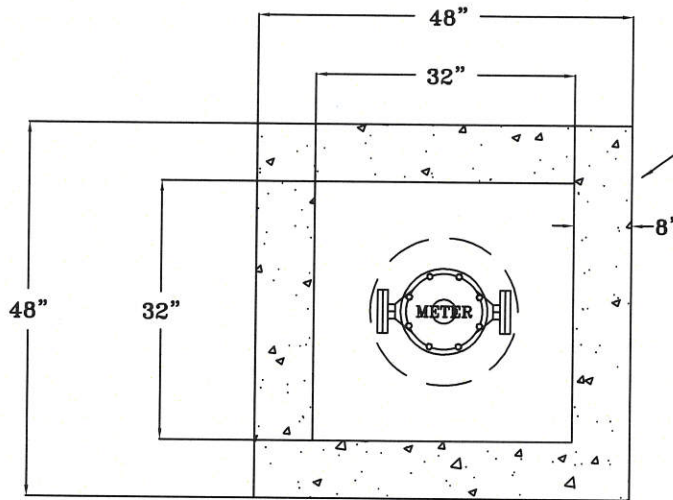

CONCRETE STRUCTURE TO BE CAST IN PLACE OR PRE-CAST. (BY OWNER)

SIDE VIEW

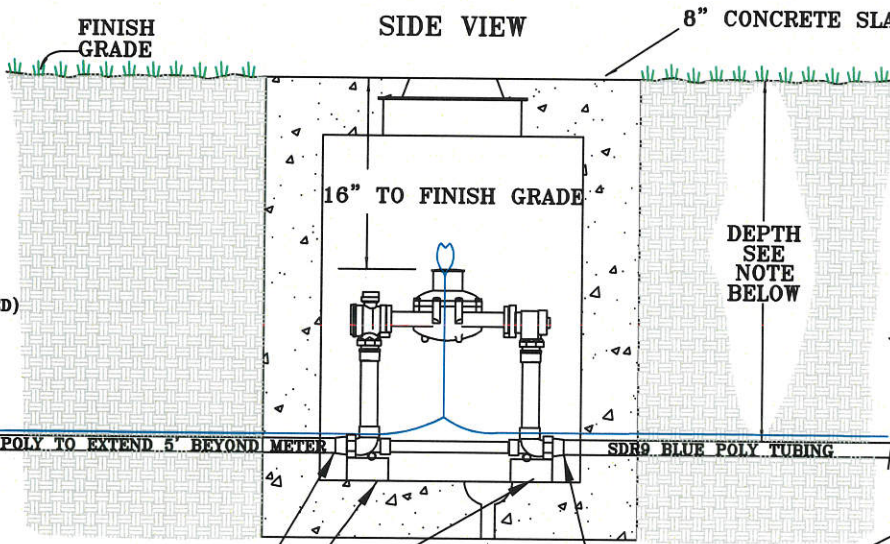

TRACER WIRE (REQUIRED) SEE NOTE BELOW

SDR9 BLUE POLY TO EXTEND 5' BEYOND METER

8" CONCRETE SLAB ADEQUATE FOR TRAFFIC

DEPTH SEE NOTE BELOW

TAPPING SLEEVE OR MJ TEE WITH 4" OUTLET

4" MJ GATE VALVE

SS Insert for 2" Poly Tubing

Concrete or Brick Supports

4" MJ END PLUG TAPPED 2" WITH 2" M.I.P. TO 2" GRIPPER, (FORD C84-77G or AYM 74753G2). Install SS insert for 2" Poly Tubing.

SS Insert for 2" Poly Tubing

4" DRAIN TO DAYLIGHT OR FRENCH DRAIN.

Notes:

1. For a 2" meter, meter set shall be Ford VBH77-18-44-77-G or AYM 721-718WDGG 770.
2. Stainless steel inserts shall installed at each connection with poly tubing.
3. Tracer wire is required on poly tubing with at least 5' inside meter pit. It is recommended to install tracer wire from meter pit to structure. See detail #9 for installation.
4. All materials shown, with the exception of the meter are the responsibility of the Owner.
5. Meter by-pass will not be allowed.
6. Depth as needed for top of meter to be 16" below finished grade.

ROLLA MUNICIPAL UTILITIES  
102 WEST 9TH STREET  
ROLLA, MISSOURI 65401

2" METER PIT FOR AREAS SUBJECT TO VEHICULAR TRAFFIC



WATER SPECIFICATIONS  
DETAIL #03

SCALE N/A REVISION DATE 03-18-2019



PLAN VIEW

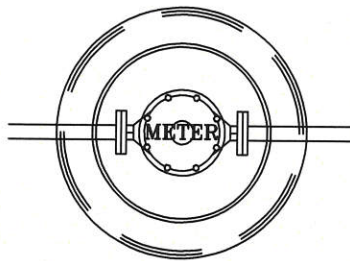

SIDE VIEW

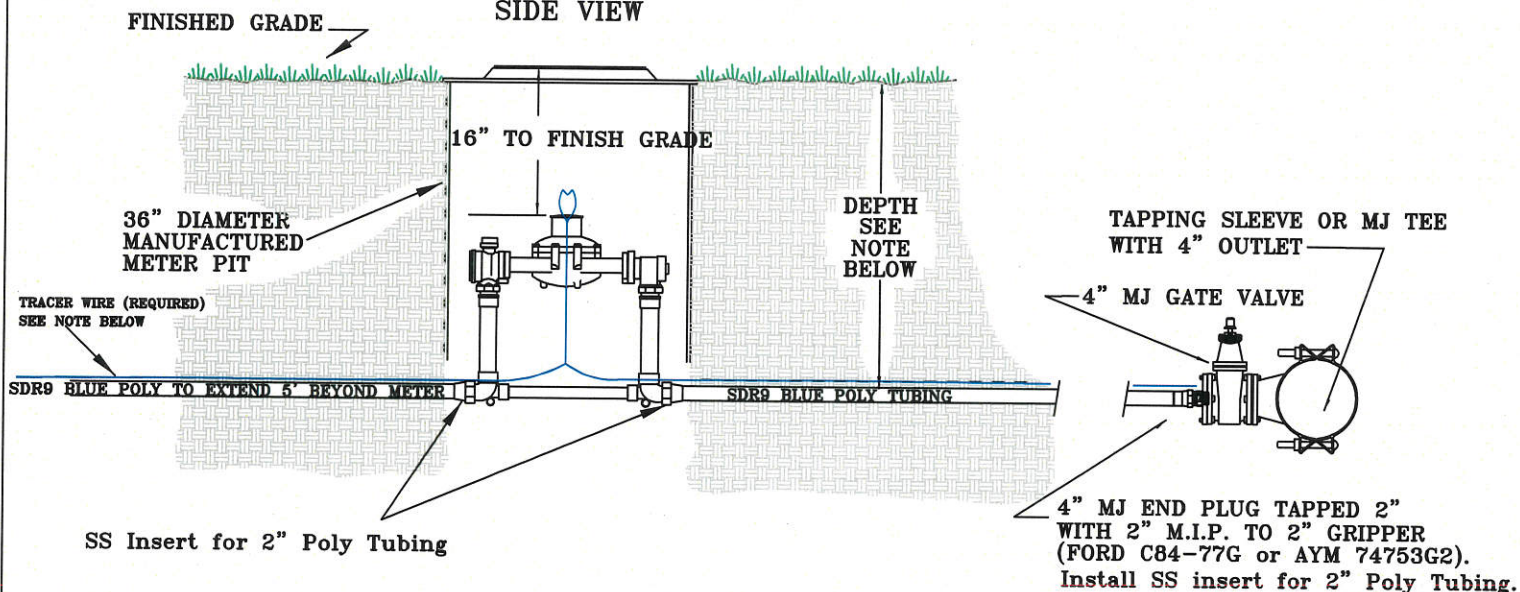

Notes:

1. For a 2" meter, meter set shall be Ford VBH77-18-44-77-G or AYM 721-718WDGG 770.
2. Stainless steel inserts shall be installed at each connection with poly tubing.
3. Tracer wire is required on poly tubing with at least 5' inside meter pit. It is recommended to install tracer wire from meter pit to structure. See detail #9 for installation.
7. For a new installation where the service will be a direct customer of RMU the meter pit, ring, and lid will be provided by RMU for installation by the Owner where the pit is not located in a traffic area. For all customers located such that the property will be served by Phelps County Water Supply District Number 2 the Owner will be required to provide all materials (other than the meter).
8. All materials shown, with the exception of the meter are the responsibility of the Owner.
9. Meter by-pass will not be allowed.
10. Depth as needed for top of meter to be 16" below finished grade.

<p><b>ROLLA MUNICIPAL UTILITIES</b>          102 WEST 9TH STREET          ROLLA, MISSOURI 65401</p>	
<p><b>2" METER PIT FOR AREAS NOT          SUBJECT TO VEHICULAR TRAFFIC</b></p>	
	<p><b>WATER SPECIFICATIONS          DETAIL #04</b></p>
<p>SCALE <u>N/A</u> REVISION DATE <u>03-18-2019</u></p>	

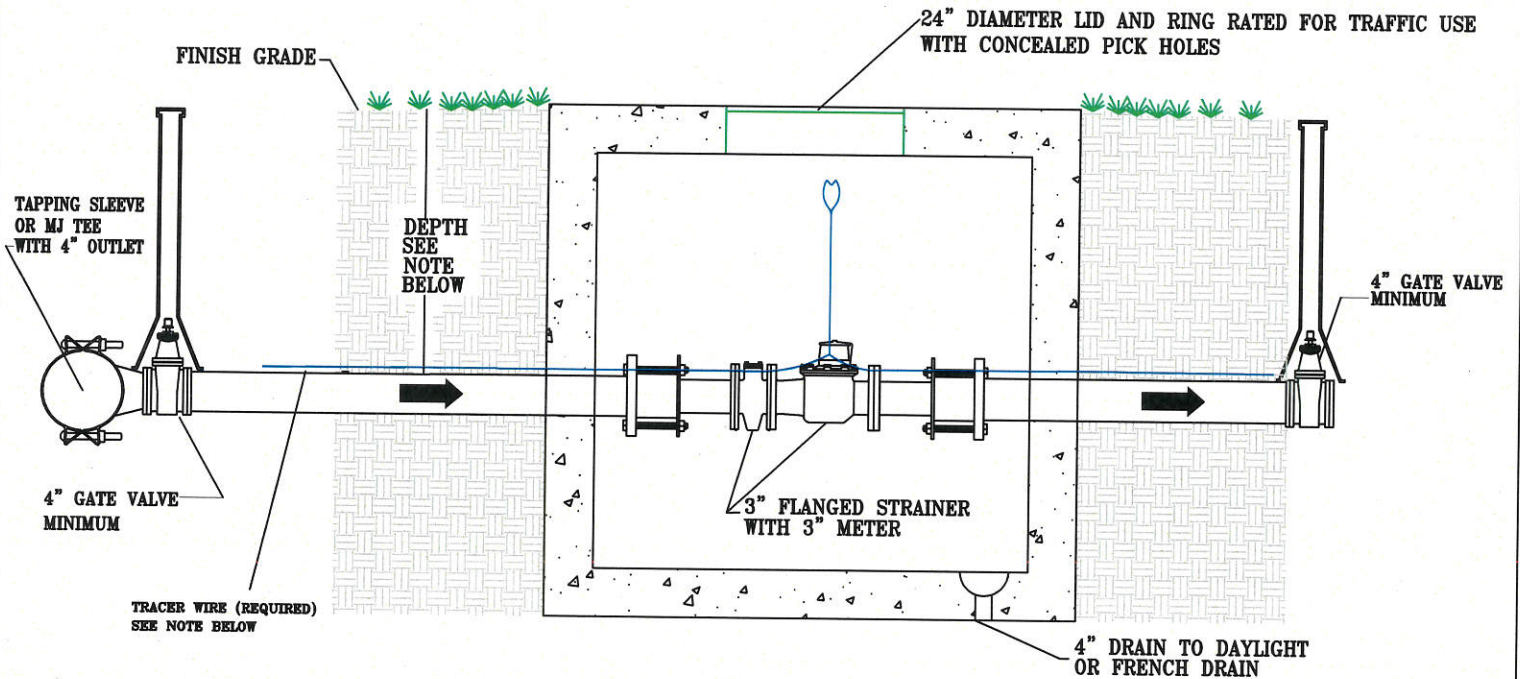
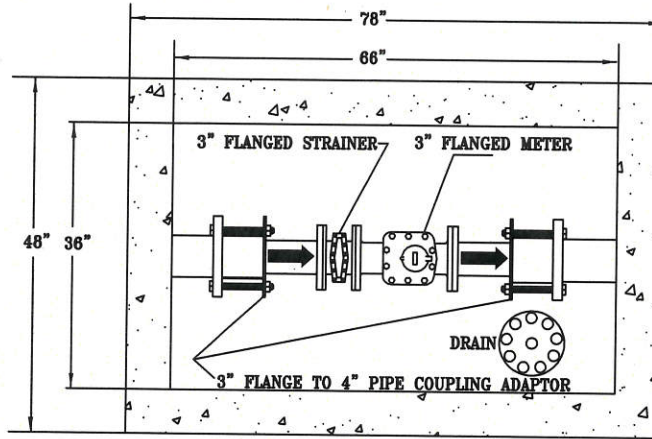

**Notes:**

1. The meter shall be placed under the center of the meter lid cover.
2. Depth as needed for top of meter to be 16" below finished grade.
3. Water service line must be valved on both sides of the meter pit. Service line reduction shall be accomplished using SMITH BLAIR (Cat #914-0480-03) or FORD (Cat #FCA4.80-D3R) Coupling Adaptor, 3" Flange to 4" Pipe, Type 914. The service line on one side of the meter shall be cut 1/2" to 1" short to allow for installation and removal of the meter.
4. Provide masonry support for meter.
5. All materials shown, with the exception of the meter and strainer are the responsibility of the owner.
6. Tracer wire is required on all mains with at least 5' inside meter pit. It is recommended to install tracer wire from meter pit to structure. See detail #9 for installation.
7. Meter bypass will not be allowed.

ROLLA MUNICIPAL UTILITIES  
 102 WEST 9TH STREET  
 ROLLA, MISSOURI 65401

**3" METER PIT**



WATER SPECIFICATIONS  
 DETAIL #05

SCALE N/A REVISION DATE 03-18-2019

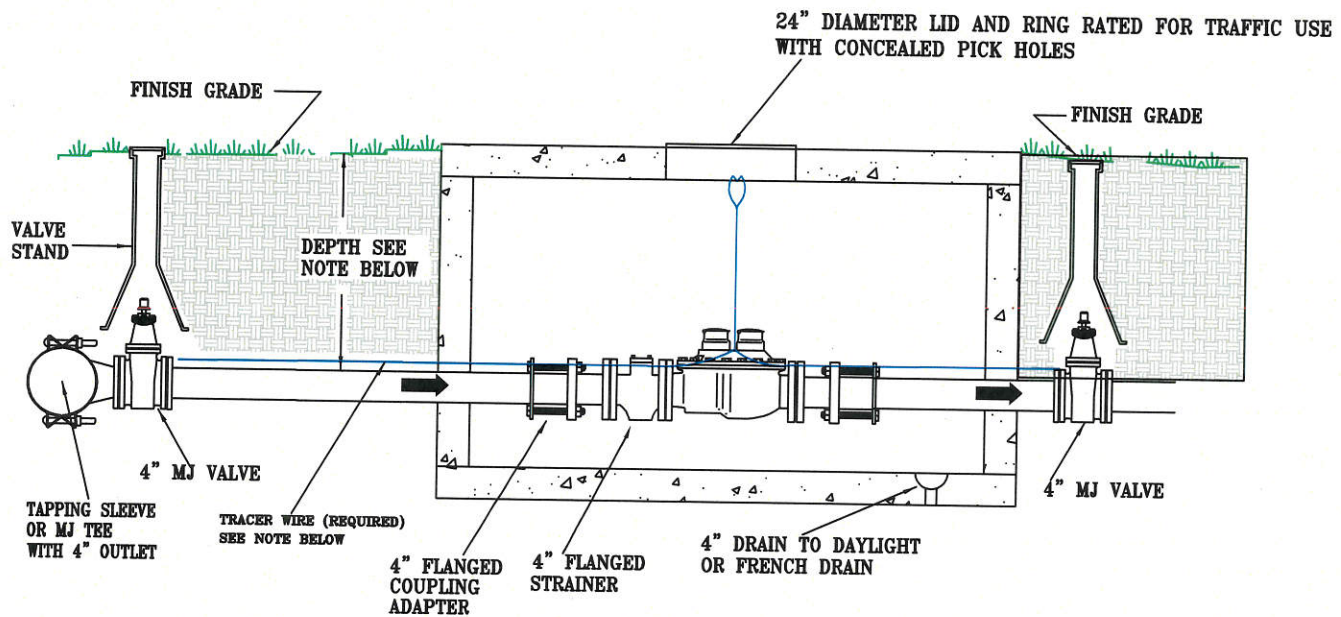
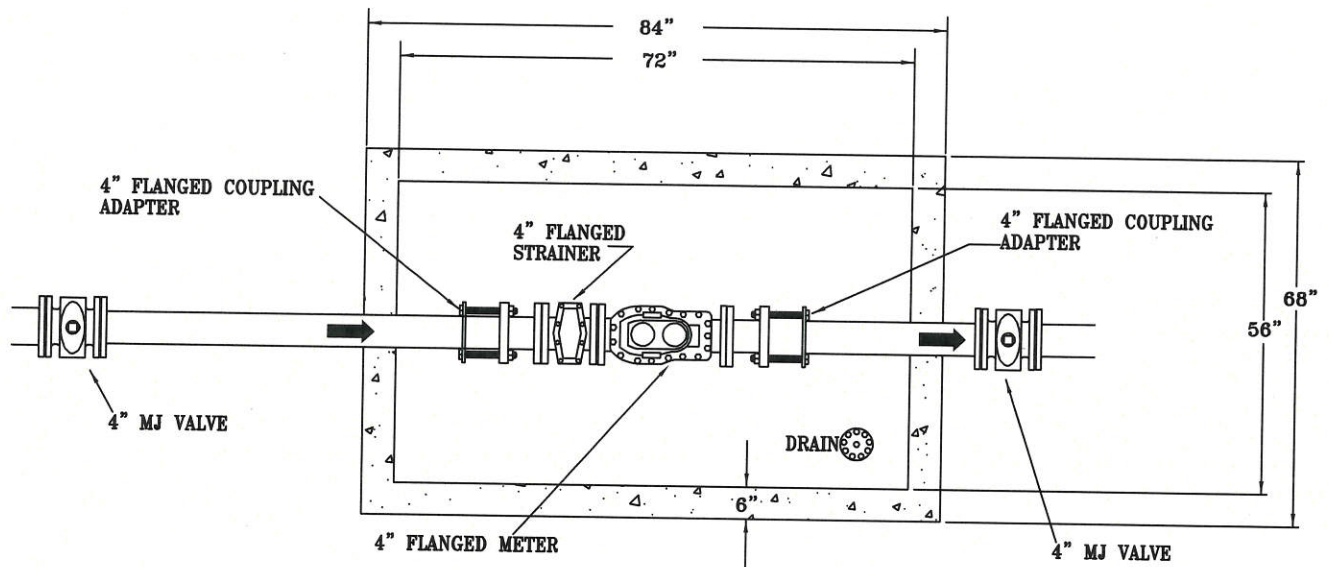

**Notes:**

1. The meter shall be placed under the center of the meter lid cover.
2. Depth as needed for top of meter to be 16" below finished grade.
3. Water service line must be valved on both sides of the meter pit.
4. Provide masonry support for meter.  
All materials shown, including the meter are the responsibility of the Owner.
5. Tracer wire is required on all mains with at least 5' inside meter pit. It is recommended to install tracer wire from meter pit to structure. See detail #9 for installation.
6. Meter bypass will not be allowed.

ROLLA MUNICIPAL UTILITIES  
102 WEST 9TH STREET  
ROLLA, MISSOURI 65401

**4" COMPOUND METER PIT**



**WATER SPECIFICATIONS  
DETAIL #06**

SCALE N/A REVISION DATE 03-18-2019

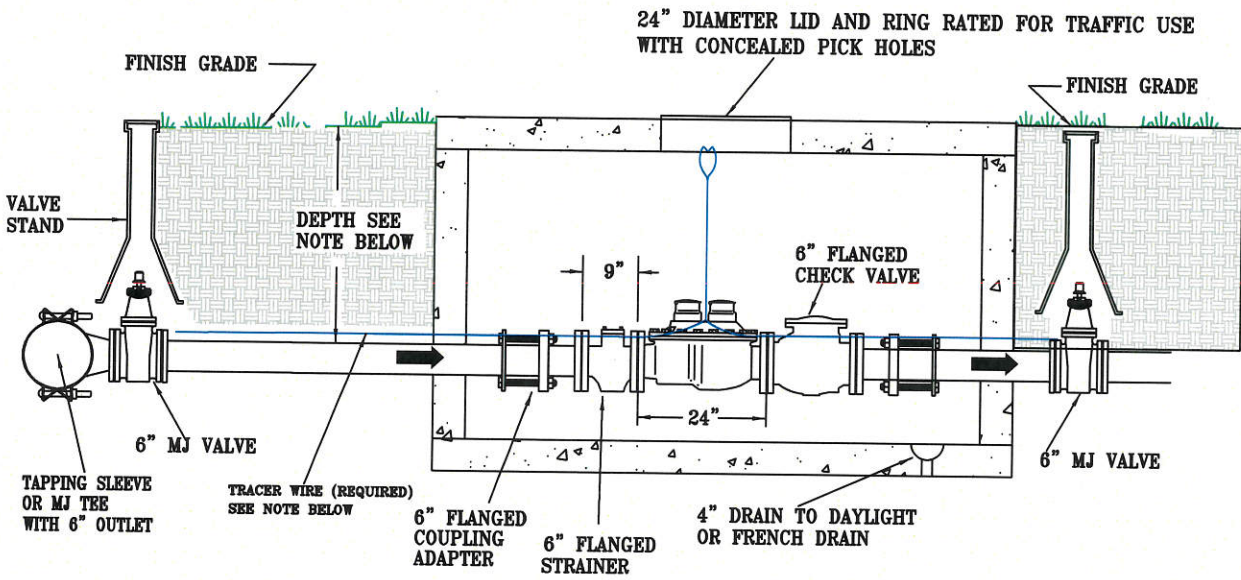
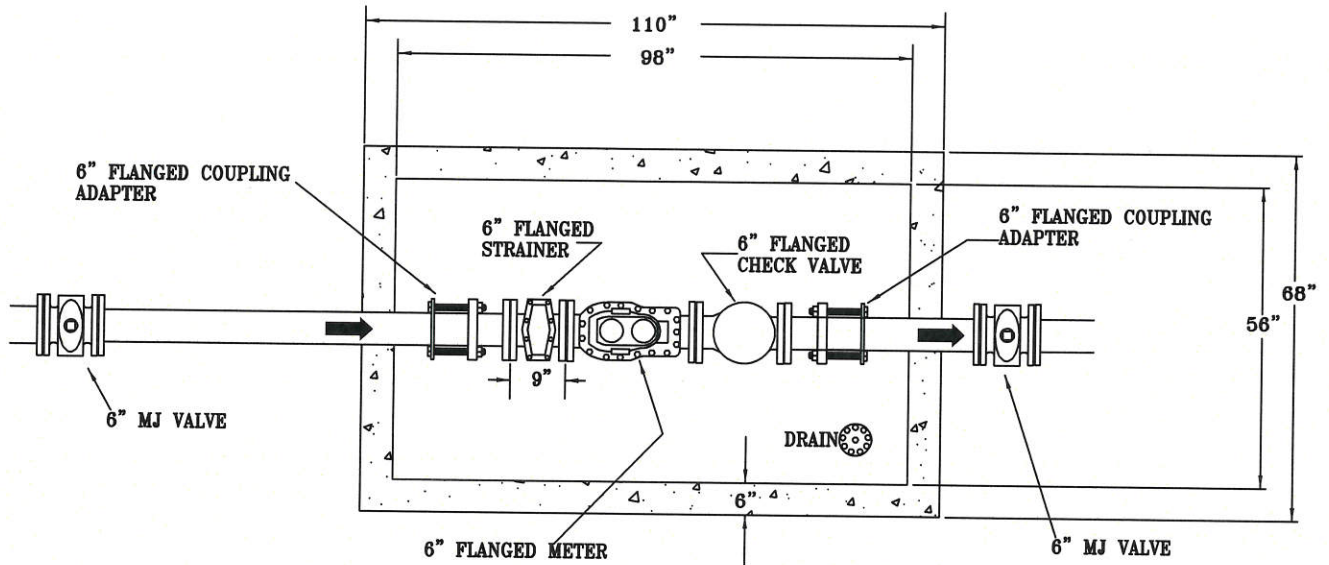

**Notes:**

1. The meter shall be placed under the center of the meter lid cover.
2. Depth of pit will be determined by the depth of the existing water mains.
3. Water service line must be valved on both sides of the meter pit.
4. Provide masonry support for meter.
5. All materials shown, including the meter are the responsibility of the Owner.
6. Tracer wire is required on all mains with at least 5' inside meter pit. It is recommended to install tracer wire from meter pit to structure. See detail #9 for installation.
7. Meter bypass will not be allowed.

<b>ROLLA MUNICIPAL UTILITIES</b> 102 WEST 9TH STREET ROLLA, MISSOURI 65401	
<b>6" COMPOUND METER PIT</b>	
	<b>WATER SPECIFICATIONS</b> <b>DETAIL #07</b>
SCALE <u>N/A</u> REVISION DATE <u>03-18-2019</u>	

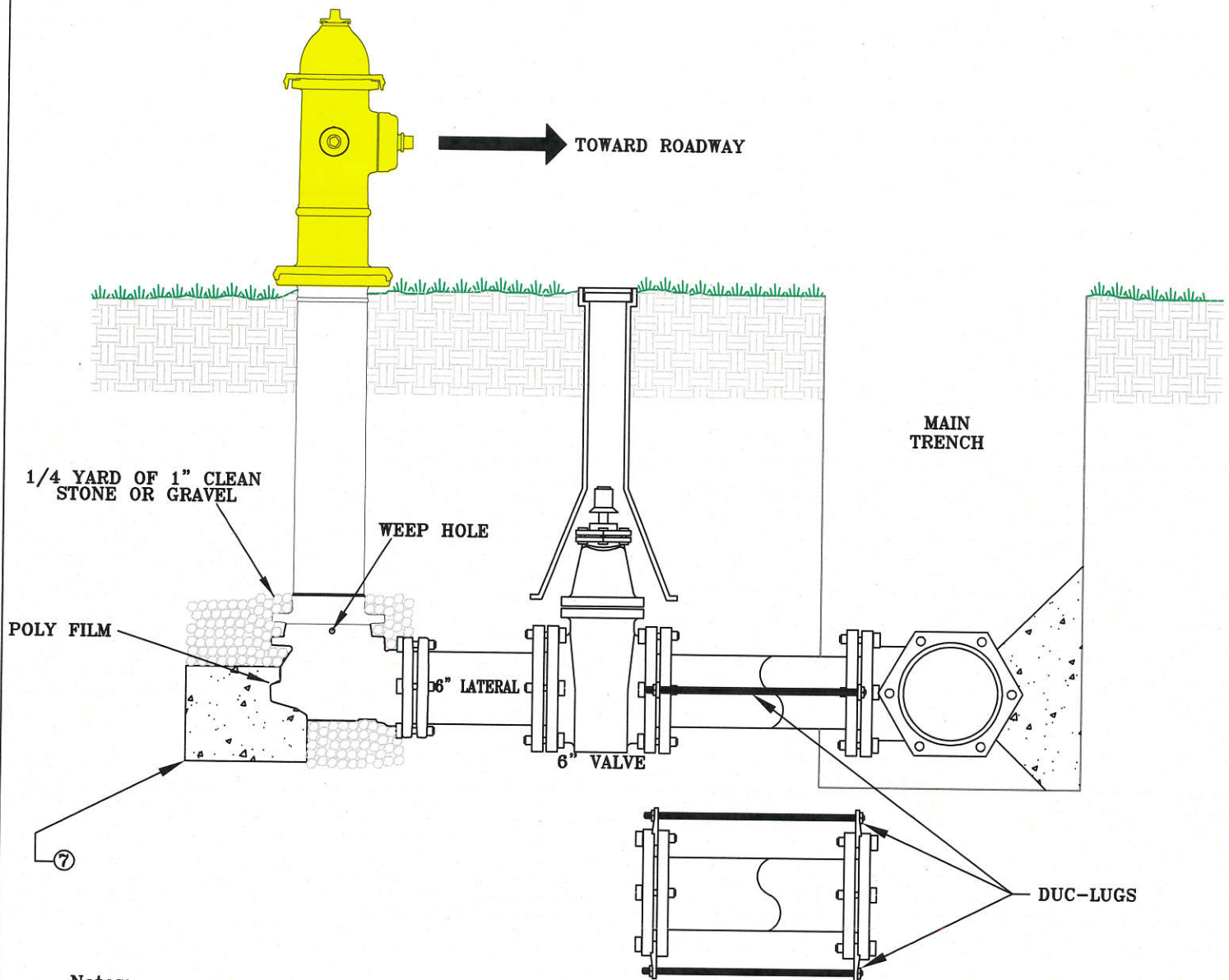

**Notes:**

1. All fire hydrants shall fully conform to AWWA C-502.
2. All three-way hydrants shall be Mueller#A423 Centurion, Clow Medallion or AVK Series 2780, 5 1/4" valve with six (6) inch mechanical joint shoe. Three way hydrants shall be adapted with one (1) 4 1/2" "Steamer" connection as pumper nozzle and two 2 1/2" hose connections (4 threads per inch).
3. All two-way hydrants shall be Mueller#A425, Clow Medallion or AVK Series 2756, 5 1/4" valve with six (6) inch mechanical joint shoe. Two-way hydrants shall be adapted with two (2) 4 1/2" "Steamer" connections as pumper nozzles (4 threads per inch).
4. Two-way hydrants shall be installed on all mains sized 12" and larger.
5. Color of all hydrants is to be safety yellow.
6. Forty-two inch bury shall be standard, however individual conditions may warrant deviation, any deviation in depth shall be approved by RMU.
7. Pour a minimum 6 cubic feet of concrete blocking against 6 square feet of undisturbed earth. That area of fire hydrant associated with the hydrant thrust block shall be wrapped with 3 mil polyethylene to insure concrete does not contact any portion of the hydrant.
8. No hydrant shall be connected to, or located within 10 feet of sanitary or storm sewers.

<b>ROLLA MUNICIPAL UTILITIES</b> 102 WEST 9TH STREET ROLLA, MISSOURI 65401	
<b>FIRE HYDRANT INSTALLATION</b>	
	<b>WATER SPECIFICATIONS</b> <b>DETAIL #08</b>  SCALE <u>N/A</u> REVISION DATE <u>03-16-2019</u>

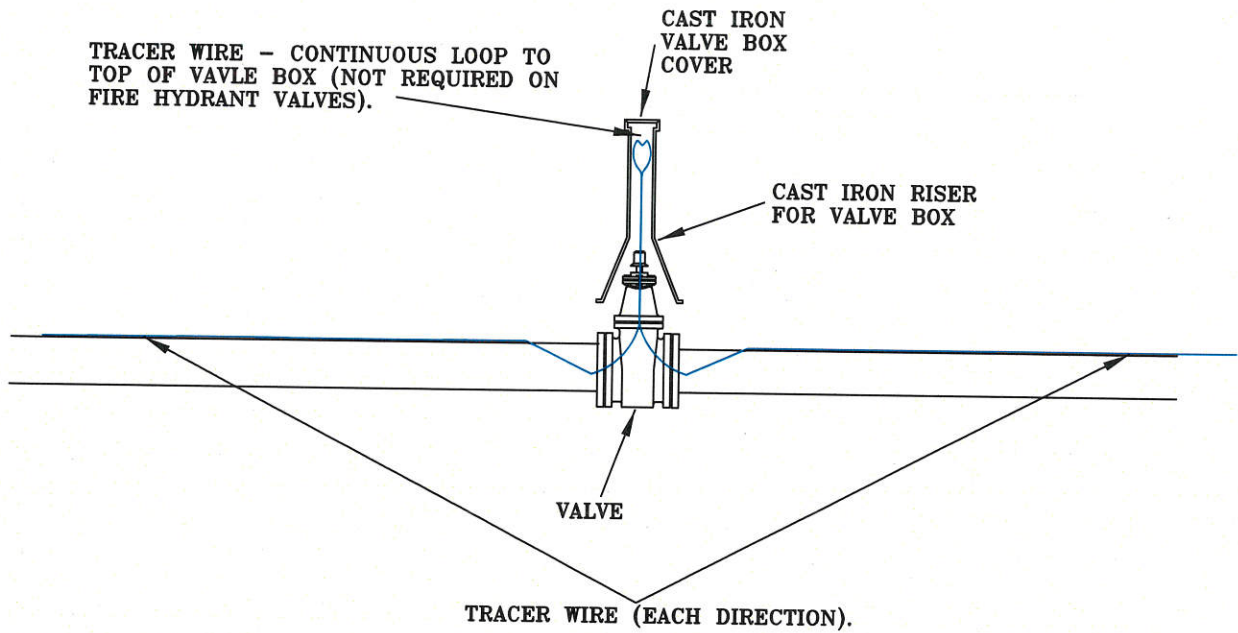

TRACER WIRE SHALL BE SECURED TO THE TOP OF THE MAIN BY TAPE A MINIMUM OF THREE TIMES IN EACH LENGTH OF PIPE.

INSTALL TRACER WIRE IN A CONTINUOUS LOOP INSIDE METER PIT. TRACER WIRE IS REQUIRED ON WATER MAIN SIDE OF METER TO 5' BEYOND METER PIT. RECOMMENDED INSTALLATION TO STRUCTURE TO FACILITATE FUTURE LOCATES OF SERVICE LINE.

TRACER WIRE FOR THE SERVICE SHALL BE CONNECTED TO THE TRACER WIRE ON THE MAIN BY A BLACKBURN 9H SPLIT BOLT AND GHFC GEL H-FRAME CLOSURE.

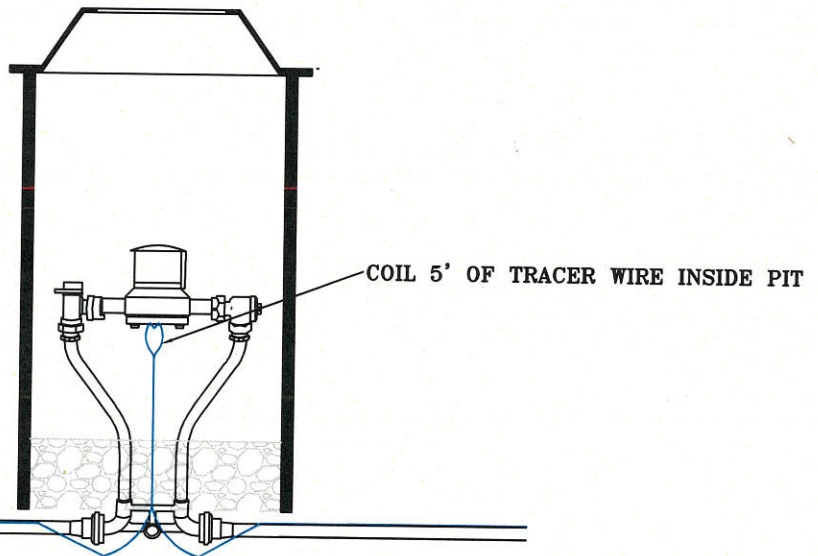

TRACER WIRE SHALL BE SECURED TO THE TOP OF THE POLY BY TAPE A MINIMUM OF EVERY 10'.

ROLLA MUNICIPAL UTILITIES 102 WEST 9TH STREET ROLLA, MISSOURI 65401	
<b>TRACER WIRE INSTALLATION</b>	
	WATER SPECIFICATIONS DETAIL #09
	SCALE <u>N/A</u> REVISION DATE <u>03-18-2019</u>

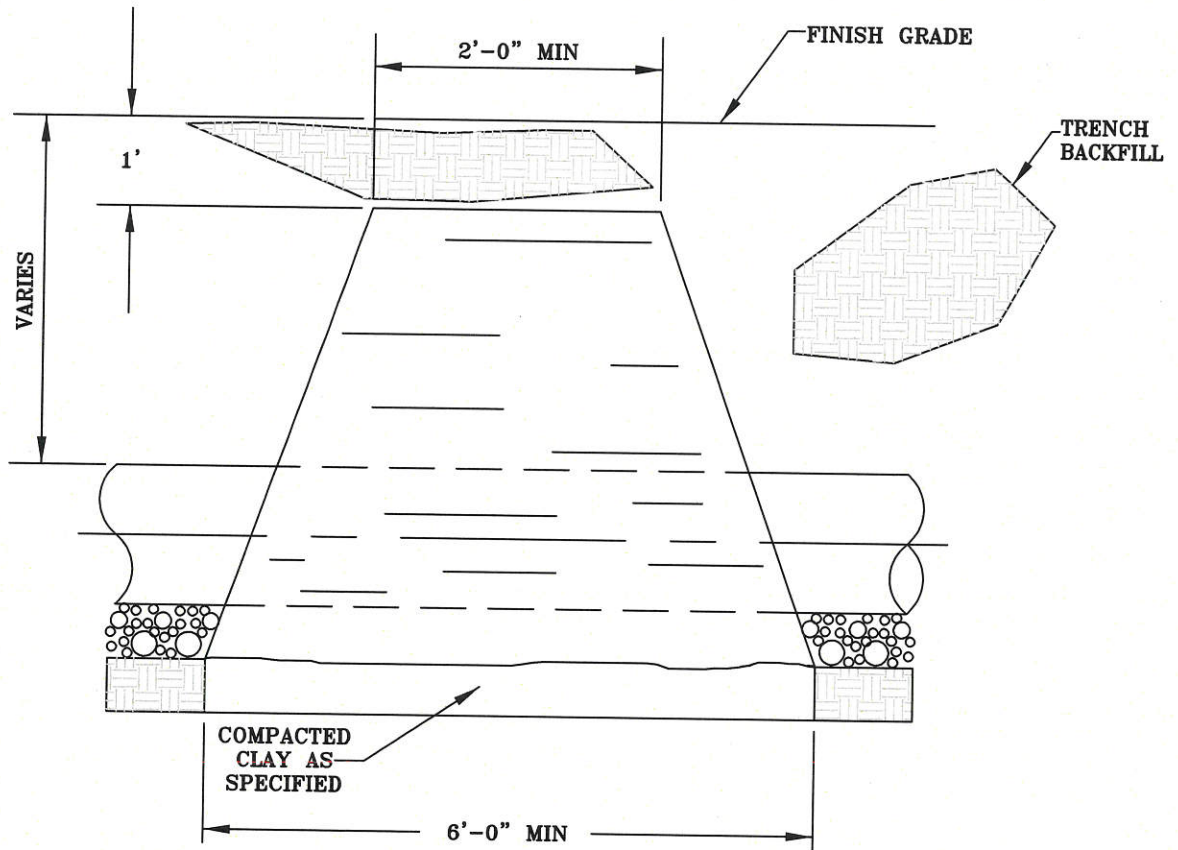

<b>ROLLA MUNICIPAL UTILITIES</b> 102 WEST 9TH STREET ROLLA, MISSOURI 65401	
<b>TRENCH CHECK</b>	
 <p>Rolla Municipal Utilities  <b>RMU</b>          People You Know. Service You Trust</p>	<b>WATER SPECIFICATIONS</b> <b>DETAIL #10</b> SCALE <u>N/A</u> REVISION DATE <u>03-18-2019</u>

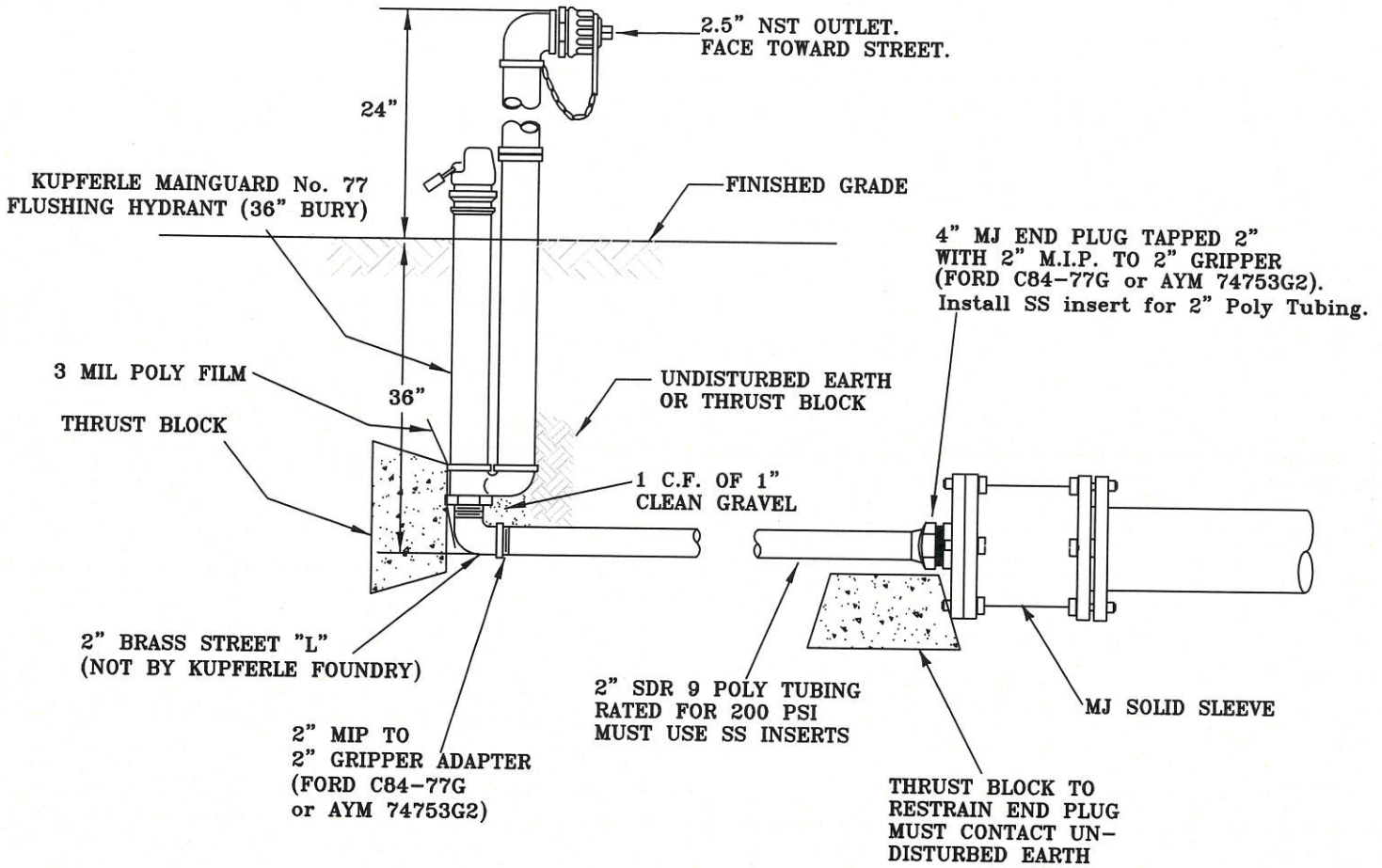

HYDRANT FACES  
STREET

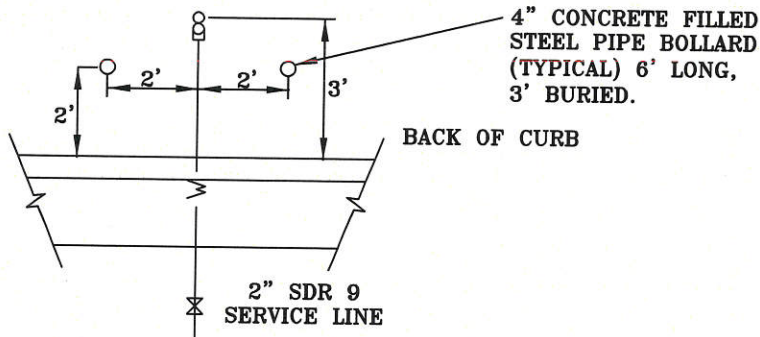

**Notes:**

1. Flush hydrants shall be non-freezing, self draining type with a 36" bury.
2. Flush hydrants shall be furnished with a 2" FIP inlet, a non-turning operating rod, and shall open to the left. All working parts shall be bronze-to-bronze design, and be serviceable from above grade with no digging. The outlet shall also be bronze and be 2 1/2" NST.
3. Flush hydrants shall be lockable to prevent unauthorized use.
4. Flush hydrants shall be as manufactured by Kupferle Foundry, or RMU approved equal.

ROLLA MUNICIPAL UTILITIES  
102 WEST 9TH STREET  
ROLLA, MISSOURI 65401

**FLUSH HYDRANT**



WATER SPECIFICATIONS  
DETAIL #11

SCALE N/A REVISION DATE 03-18-2019



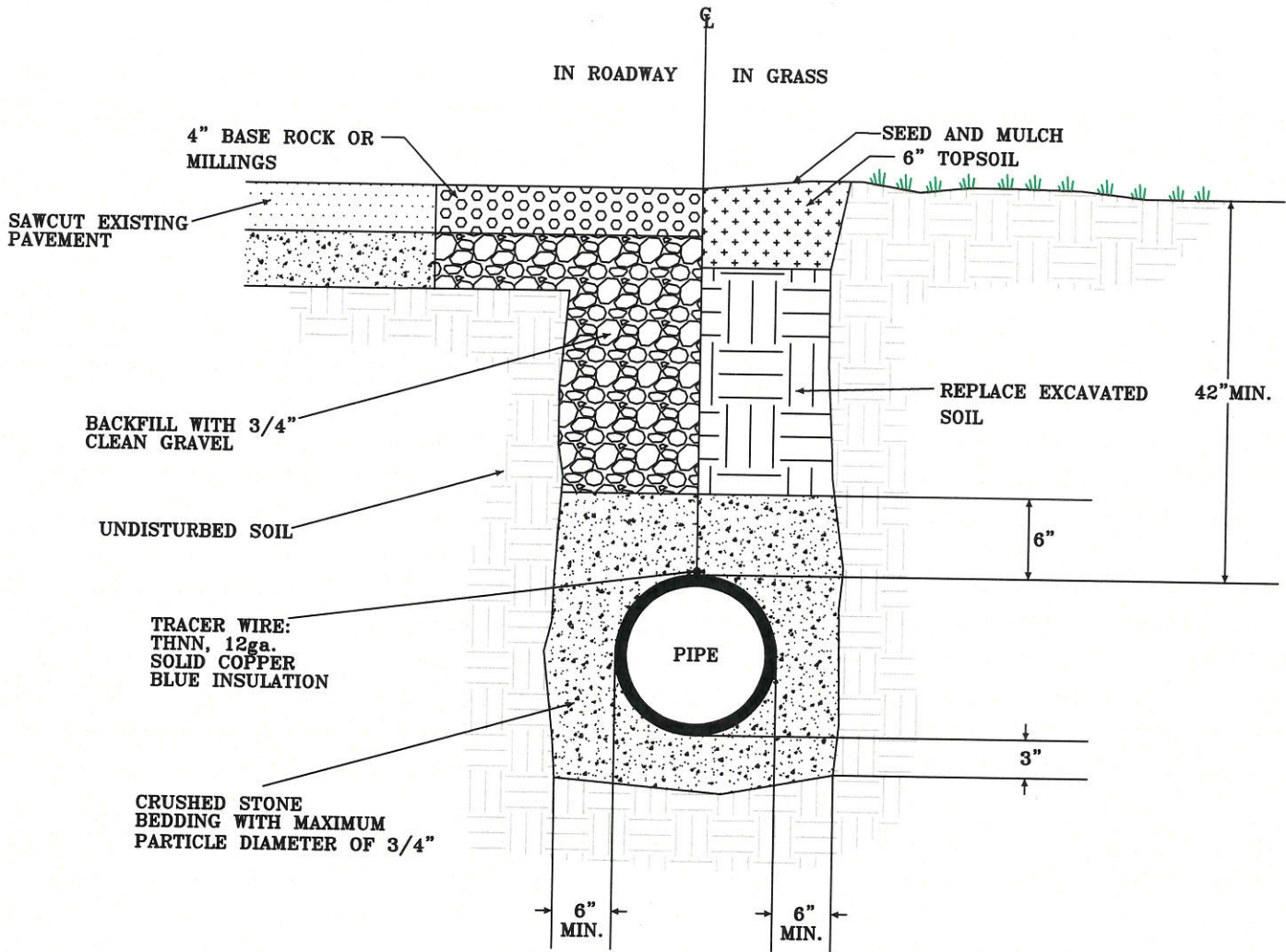

**Notes:**

1. Bedding material shall be crushed stone aggregate with 100% passing a 1" screen, 95% passing a 3/4" screen and not more than 5% passing a No. 4 screen.
2. City of Rolla to determine pavement requirements.

<b>ROLLA MUNICIPAL UTILITIES</b> 102 WEST 9TH STREET ROLLA, MISSOURI 65401	
<b>TRENCH BACKFILL</b>	
	<b>WATER SPECIFICATIONS</b> DETAIL #12 SCALE <u>N/A</u> REVISION DATE <u>03-18-2019</u>

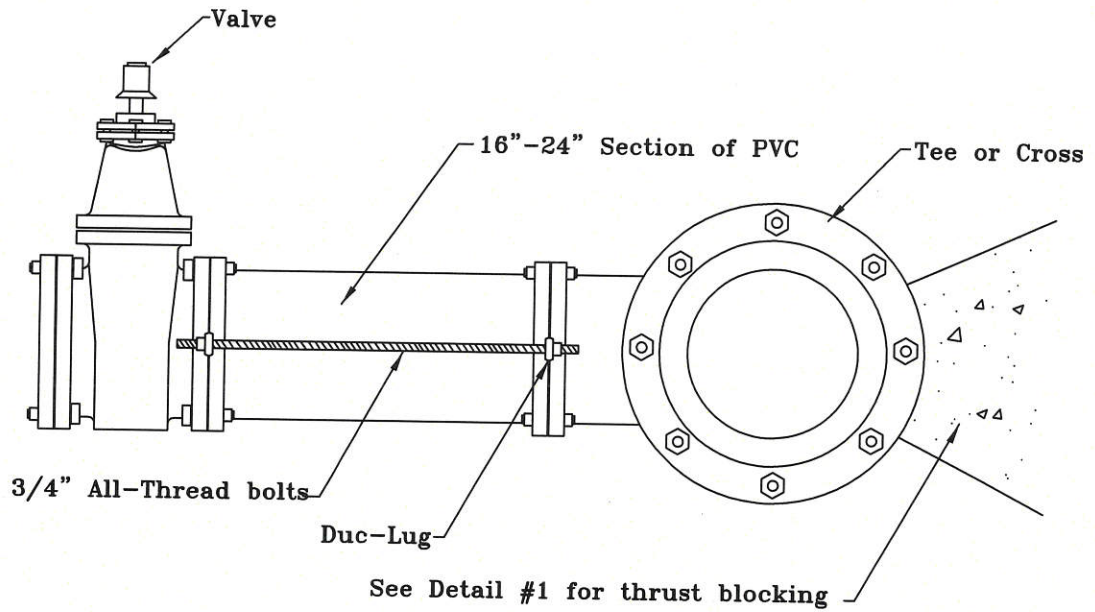

1. All valves associated with a tee or cross shall be restrained with Duc-lugs and All-thread bolts in the quantity described in the table below.
2. There shall be a 16"-24" section of pipe installed between the valve and tee or cross.
3. Refer to Detail #1 for thrust blocking requirements.

DUC LUG & ALL-THREAD BOLT REQUIREMENTS		
VALVE SIZE	NO. OF DUC LUGS	NO. BOLTS
4"	4	2
6"	4	2
8"	8	4
10"	12	6
12"	16	8
16"	20	10

<b>ROLLA MUNICIPAL UTILITIES</b> 102 WEST 9TH STREET ROLLA, MISSOURI 65401	
<b>VALVE RESTRAINT AT TEES          AND CROSSES FOR LINES 6" - 16"</b>	
	<b>WATER SPECIFICATIONS</b> <b>DETAIL #13</b>
	SCALE <u>N/A</u> REVISION DATE <u>03-18-2019</u>